

- RU** Шланги, сварные сливы и фитинги с резьбой
TR Esnek hortum, kaynak maşonları ve dişli fittingler (eklemeler)



Flexible Hose

Шланг
Esnek hortum

P. 6.002



Drop Nipples

Штуцеры
Barometrik borular

P. 6.003



Branch Outlets [Threaded/Grooved]

Сливы для ветвей [с резьбой/пазами]
Kaynak maşonları [dişli/yivli]

P. 6.005



Pipe Thread Sealant

Герметик для резьбы труб
Dişli borular için sızdırmaz dolgu maddesi

P. 6.010



Welding Neck Flanges

Сварные торцевые насадки
Kaynak yakası flanşlar

P. 6.011



Flange Bolting Kits

Наборы для соединительных фланцев
Flanş civata seti

P. 6.012

Flexible Hose

- RU** Шланг
TR Esnek hortum



FASTFLEX

Model Fastflex - 1" BSP Female

Art. No.	Type	Hose Length Длина шланга Hortum uzunluğu	Internal Ø Внутренний Ø İç kısım Ø	Equivalent Loss Straight Эквив. потери - прямое положение Eşdeğer kayıp (düz)	Equivalent Loss 90° Bend Эквив. потери - изгиб на 90° Eşdeğer kayıp 90° (bükülmüş)	Kg	UL	FM	VDS	LPCB	APCAD
		[mm]	[mm]	[m]	[m]						
YN250700	Un-braided/Без оплетки/Örgüsüz	700	25	7.60	7.60	0.7	✓			✓	✓
YN251000	Un-braided/Без оплетки/Örgüsüz	1000	25	10.35	17.08	0.9	✓			✓	✓
YN251200	Un-braided/Без оплетки/Örgüsüz	1200	25	12.19	23.40	1.0	✓			✓	✓
YN251500	Un-braided/Без оплетки/Örgüsüz	1500	25	15.24	29.25	1.2	✓			✓	✓
YB280700	Braided/С оплеткой/Örgülü	700	28	3.00	5.18	0.7	✓		✓	✓	✓
YB281000	Braided/С оплеткой/Örgülü	1000	28	4.67	6.64	0.9	✓		✓	✓	✓
YB281200	Braided/С оплеткой/Örgülü	1200	28	5.79	7.62	1.0	✓		✓	✓	✓
YB281500	Braided/С оплеткой/Örgülü	1500	28	7.24	9.53	1.2	✓		✓	✓	✓
YB280700-F	Braided/С оплеткой/Örgülü	700	28	3.00	5.18	1.9		✓			
YB281000-F	Braided/С оплеткой/Örgülü	1000	28	4.67	6.64	1.5		✓			
YB281200-F	Braided/С оплеткой/Örgülü	1200	28	5.79	7.62	1.6		✓			
YB281500-F	Braided/С оплеткой/Örgülü	1500	28	7.24	9.53	1.9		✓			

Max. 12.1 bar [175 psi]

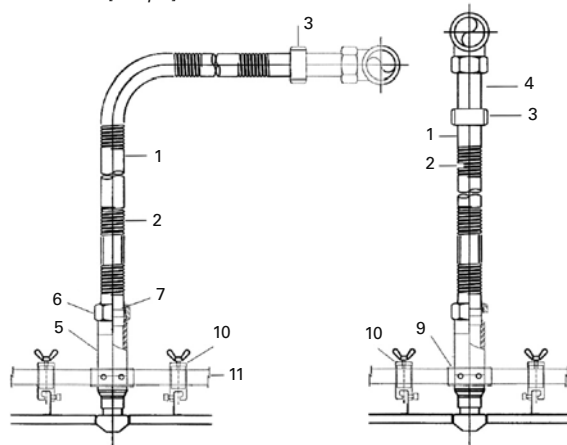

Parts List/Список деталей/Parçalar listesi

No.	Description Описание Tanımlama	Material Материал Ürün	Qty Кол-во Aded
1	Flexible Tube/Гибкая трубка/Esnek hortum	SS AISI 304	1
2	Weaver/Оплетка/Örme	SS AISI 304	1
3	Braid Ring/Плетеное кольцо/Örme halkası	Mild Steel/Мягкая сталь/Yumuşak çelik	2
4	Nipple/Патрубок/Меме başı	Mild Steel/Мягкая сталь/Yumuşak çelik	1
5*	Sprinkler Reducer/Переходник для спринклера/Sprinkler reduksiyonu	Mild Steel/Мягкая сталь/Yumuşak çelik	1
6	Slip Nut/Опорная гайка/Kayan somun	Brass/Латунь/Pirinç	1
7	O-Ring/Плотнительное кольцо/O halkası	NBR/CR	2
8	Washer/Шайба/Rondela	Nylon W6	2
9	Bracket/Держатель/Mesnetler	Pressed Steel/Штампованная сталь/Sıkıştırılmış çelik	1
10*	Clamps/Зажимы/Kelepçeler	Pressed Steel/Штампованная сталь/Sıkıştırılmış çelik	2
11	Support bar/Опорная планка/Destekleme aleti	Pressed Steel/Штампованная сталь/Sıkıştırılmış çelik	1

*Note part 5: Sprinkler Reducer is straight, 1/2" NPT thread. Elbows 45° or 90° and 3/4" NPT Connections available on request.

*Note part 10: Standard Clamp to be used for Recessed Sprinklers. Special Clamp for Concealed Sprinklers available on request.

*Прим.к детали 5: Спринклерный переходник прямой, резьба 1/2" NPT. Колена 45° или 90° и соединительные элементы с резьбой 3/4" NPT - по запросу.

*Прим. к детали 10: Стандартный зажим использовать для утопленных спринклеров. Специальный зажим для скрытых спринклеров - по запросу.

*Not 5. bölüm: Sprinkler reduksiyonu düzdür, 1/2" NPT dişlisi. Dirsekler 45° veya 90°dir. 3/4" bağlantıları istek üzere sunulmaktadır.

*Not 10. bölüm: Gömme sprinklerler ile kullanılacak standart kelepçeler Gizli sprinklerler ile kullanılabilen özel kelepçeler istek üzere sunulmaktadır.

TYCO reserves the right to change the contents without notice TYCERTFP 03/07

Drop Nipples

RU Штуцеры

TR Barometrik borular



Model Longneck

Модель Longneck

Longneck tipi barometrik boru modeli

P. 6.004



Model M & F

Модель M & F

M & F modeli

P. 6.004

Drop Nipples

- RU** Штуцеры
TR Barometrik borular



LONGNECK

Material: Schedule 40 Steel Pipe to A-53
Материал: Труба из стали Schedule 40 по A-53
Madde: 40 nolu çizelge, A-53'e uygun çelik boru

Finish: Black Polymer Coating
Отделка: Покрытие из черного полимера
Kaplama: Siyah polimer kaplama

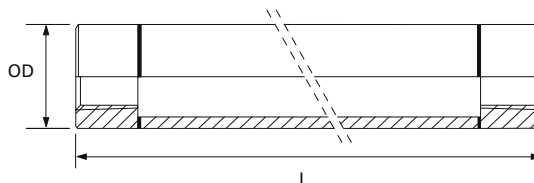

Reduced Ends Model Longneck / Концы уменьш. диам., модель Longneck /Uçları redüksiyonlu Longneck modeli

Art. No.	O.D. Size Диаметр Boyu		L* [mm]	Outlets Female Выпуски - гнездового типа Çıkışlar (dişi)	Kg	VDS	UL	FM
	DN	[mm]						
73100336	25 [1"]	33.4	932	3/8" ISO	2	✓		
73100536	25 [1"]	33.4	932	1/2" NPT	2	✓	✓	✓
73100736	25 [1"]	33.4	932	3/4" NPT	2	✓	✓	✓

*Special lengths are available upon request

* Особая длина - по запросу

*Özel uzunluklar istek üzere sunulmaktadır.

Max. 20.68 bar [300 psi]



M & F

Material Shaft: Cold formed Steel to ASTM A-53
Материал ствола: Холодноштампованная сталь по ASTM A-53

Gövde maddesi: ASTM-A-53'e uygun soğuk işlenmiş çelik

Material "O" Rings: EPDM
Материал уплот. колец: ЭПДМ

O ring halkası maddesi: EPDM

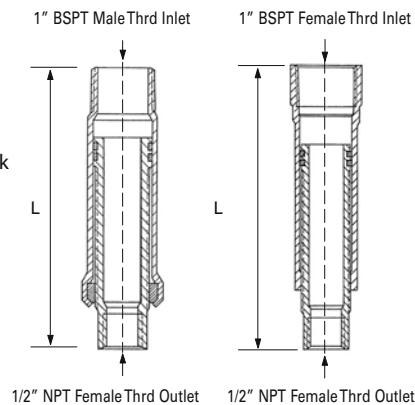

M & F

Art. No.	Inlet Size BSP Диам. впуск. отверстия		Female/Male Гнезд./штуыр. тип Dişi/erkek	Outlet Size NPT Диам. вып. отверстия, NPT Çıkış boyu NPT		Min. L mm	Max. L mm	Adjustment Range Диапазон регулировки Ayarlama aralığı	Kg	VDS	UL	FM
	mm	mm		mm	mm							
14034212	1"	25	F	1/2"	15	89	114	25	0.36	✓	✓	✓
14534212	1"	25	F	1/2"	15	114	165	51	0.45	✓	✓	✓
16034212	1"	25	F	1/2"	15	140	216	76	0.57	✓	✓	✓
16534212	1"	25	M	1/2"	15	105	130	25	0.45	✓	✓	✓
15034212	1"	25	M	1/2"	15	156	232	76	0.57	✓	✓	✓
15534212	1"	25	M	1/2"	15	200	276	76	0.68	✓	✓	✓

Max. 20.68 bar [300 psi] for Sprinkler systems/для спринклерных систем/Max.20.68 bar [300 psi] sistemler için

TYCERTFP 03/07 Tyco reserves the right to change the contents without notice

Branch Outlets [Threaded/Grooved]

RU Сливы для ветвей [с резьбой/пазами]

TR Kaynak manşonları



Branch Outlets

Сливы для ветвей
Kaynak manşonlar

P. 6.006



Branch Outlets, Non-Chamfered

Сливы для ветвей, лицевая сторона не скошена
Şamfersiz bransman manşonları

P. 6.007



Welding Branchlets Grooved

Сварные ветви с пазами
Kaynak manşonları, yivli

P. 6.008



C-Let Grooved Non-Chamfered

Патрубок С с пазами, лицевая сторона не скошена
C-Let yivli, şamfersiz

P. 6.009

Branch Outlets Threaded

RU Слив для ветвей, с резьбой

TR Bransman manşonları, yivli



TEE-LET THREADED

Material: Black Steel to ASTM A-53
Материал: Черная сталь по ASTM A-53
Madde: ASTM A-53'e uygun siyah çelik

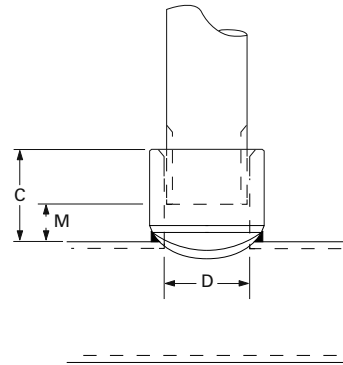

Tee-Let Threaded / Патрубок с Т-образным отверстием, резьба / T-Let yivli

Art. No.	Outlet Size Female		Header for Pipe Size		Outlet Length	Inside Ø	Make Up		Kg	UL	FM
	Вых. отверстие гнезд. типа Çıkış boy (dişi)		Головная часть трубы, диаметр Borunun anma genişliği		Длина выпускного отверстия Çıkış uzunluğu	Внутренний Ø İç Ø çap	Типоразмер Uç açıklığı				
	DN		DN		C mm	D mm	M mm				
02042U			32-40	1.1/4"-1.1/2"	27	18	13	0.050	√	√	
02047U	15	1/2" NPT	50-65	2"-2.1/2"					√	√	
02050U			65-200	2.1/2"-8"					√	√	
02070U	20	3/4" NPT	32-40	1.1/4"-1.1/2"	29	23	13	0.075	√	√	
02074U			50-65	2"-2.1/2"					√	√	
02075U			65-200	2.1/2"-8"					√	√	
02090BU	25	1" BSP	32-40	1.1/4"-1.1/2"	32	29	13	0.100	√	√	
02097BU			50-65	2"-2.1/2"					√	√	
02102BU			80-100	3"-4"					√	√	
02105BU			125-200	5"-8"					√	√	
02120BU	32	1.1/4" BSP	40-50	1.1/2"-2"	35	38	16	0.125	√	√	
02125BU			50-65	2"-2.1/2"					√	√	
02130BU			80-100	3"-4"					√	√	
02135BU			125-200	5"-8"					√	√	
02150BU	40	1.1/2" BSP	50	2"	41	41	22	0.200	√	√	
02155BU			65	2.1/2"					√	√	
02160BU			80-100	3"-4"					√	√	
02165BU			125-200	5"-8"					√	√	
02180BU	50	2" BSP	60	2"	44	53	22	0.350	√	√	
02185BU			65	2.1/2"					√	√	
02190BU			80	3"					√	√	
02200BU			100	4"					√	√	
02205BU			125	5"					√	√	
02210BU			150	6"					√	√	
02215BU			200	8"					√	√	
02235BU	65	2.1/2" BSP	80	2.1/2"	54	63	29	0.700	√	√	
02240BU			100	3"					√	√	
02245BU			125	4"					√	√	
02260BU			150	6"					√	√	
02265BU			200	8"					√	√	

Max. 20.68 bar [300 psi] for Sprinkler systems/для спринклерных систем/Max.20.68 bar [300 psi] sistemler için

TYCERTFP 03/07 Tyco reserves the right to change the contents without notice

Branch Outlets, Non Chamfered

RU Сливы для ветвей, лицевая сторона не скошена

TR Şamfersiz branş manşonları



Material: Black Steel to ASTM A-105
Материал: Черная сталь по ASTM A-105
Madde: ASTM A-105'e uygun siyah çelik

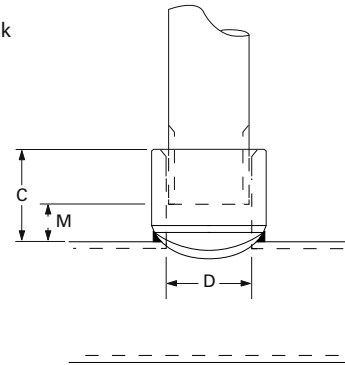

C-Let Threaded /Патрубок с С-образным отверстием, резьба /C-Let yivli

Art. No.	Outlet Size Female Вых. отверстие гнезд. типа Çıkış boy (dişi)		Header for Pipe Size Головная часть трубы, диаметр Borulup anma genişliği		Outlet Length Длина выпускного отверстия Çıkış uzunluğu		Inside Ø Внутренний Ø İç Ø çap		Make Up Типоразмер Uç açıklığı		Kg	UL	FM
	DN		DN		C mm	D mm	M mm						
TH15025NC	15	1/2" NPT	25-40	1"-1.1/2"	25	21	14	0.050			√	√	
TH15050NC			50-65	2"-2.1/2"							√	√	
TH15080NC			80-200	3-8"							√	√	
TH20025NC	20	3/4" NPT	25-40	1"-1.1/2"	25	25	14	0.075			√	√	
TH20050NC			50	2"							√	√	
TH20065NC			65	2.1/2"							√	√	
TH20080NC			80-125	3"-5"							√	√	
TH20150NC			150-200	6"-8"							√	√	
TH25032NC	25	1" BSP	32-40	1.1/4"-1.1/2"	28	33	15	0.100			√	√	
TH25050NC			50	2"							√	√	
TH25065NC			65	2.1/2"							√	√	
TH25080NC			80	3"							√	√	
TH25100NC			100-125	4"-5"							√	√	
TH25150NC			150-200	6"-8"							√	√	
TH32050NC	32	1.1/4" BSP	50	2"	32	41	16	0.128			√	√	
TH32065NC			65	2.1/2"							√	√	
TH32080NC			80	3"							√	√	
TH32100NC			100-125	4"-5"							√	√	
TH32150NC			150-200	6"-8"							√	√	
TH40050NC	40	1.1/2" BSP	50	2"	32	47	16	0.200			√	√	
TH40065NC			65	2.1/2"							√	√	
TH40080NC			80	3"							√	√	
TH40100NC			100	4"							√	√	
TH40125NC			125-150	5"-6"							√	√	
TH40200NC			200	8"							√	√	
TH50065NC	50	2" BSP	65	2.1/2"	38	59	18	0.354			√	√	
TH50080NC			80	3"							√	√	
TH50100NC			100	4"							√	√	
TH50150NC			150-200	6"-8"							√	√	
TH65100NC	65	2.1/2" BSP	100	4"	45	70	22	0.700			√	√	
TH65150NC			150	6"							√	√	
TH65200NC			200	8"							√	√	

Max. 20.68 bar [300 psi] for Sprinkler systems/для спринклерных систем/Max.20.68 bar [300 psi] sistemler için

TYCERTFP 03/07 Tyco reserves the right to change the contents without notice

Branch Outlets, Grooved

RU Сливы для ветвей, с пазами

TR Kaynak manşonları, yivli



WELDING BRANCHLETS GRV

Material: Black Steel to ASTM A-53
Материал: Черная сталь по ASTM A-53
Madde: ASTM A-53'e uygun siyah çelik

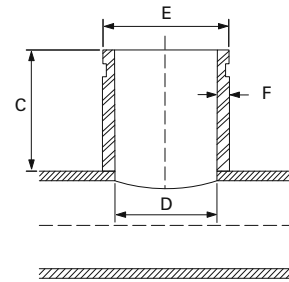

Welding Branchlets Grooved/Сварные ветви с пазами/Kaynak manşonları, yivli

Art. No.	Grooved Outlet Size Вых. отверстие с пазом Çıkış boy (dişli)		Header for Pipe Size Головная часть трубы, диаметр Borunun ana genişliği		Outlet Length Длина выpus. отверстия Çıkış uzunluğu	Inside Ø Внутренний Ø İç Ø çar	Outside Ø Внутренний Ø Dış çar	Wall Thickness Толщина стенки Düvar kalınlığı	Kg	UL	FM
	DN		DN		C mm	D mm	E mm	F mm			
13580	32	1.1/4"	50-65	2"-2.1/2"	76	35	42.2	3.6	0.125	√	√
13585			80-100	3"-4"						√	√
13590			125-200	5"-8"						√	√
13600	40	1.1/2"	50	2"	76	41	48.3	3.7	0.200	√	√
13605			65	2.1/2"						√	√
13610			80-100	3"-4"						√	√
13615			125-200	5"-8"						√	√
13625	50	2"	65	2.1/2"	76	53	60.3	3.9	0.350	√	√
13630			80	3"						√	√
13635			100	4"						√	√
13645			150	6"						√	√
13650			200	8"						√	√
13655M	65	2.1/2"	65	2.1/2"	76	67	76.1	5.2	0.700	√	√
13660M			80	3"						√	√
13665M			100	4"						√	√
13675M			150	6"						√	√
13680M			200	8"						√	√
13685	80	3"	80	3"	76	78	88.9	5.5	0.900	√	√
13695			100	4"						√	√
13705			150	6"						√	√
13710			200	8"						√	√
13715	100	4"	100	4"	102	102	114.3	6.0	1.000	√	√
13725			150	6"						√	√
13730			200	8"						√	√

Max. 20.68 bar [300 psi] for Sprinkler systems/для спринклерных систем/Max.20.68 bar [300 psi] sistemler için

Branch Outlets, Grooved, Non Chamfered

RU Слив для ветвей, с пазами, лицевая сторона не скошена

TR Şamfersiz branş manşonları, yivli



Material: Black Steel to ASTM A-53
Материал: Черная сталь по ASTM A-53
Madde: ASTM A-53'e uygun siyah çelik

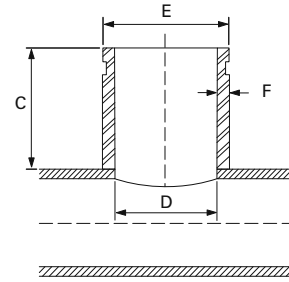

C-Let Grooved Non-Chamfered / Патрубок с С-образным отверстием, с пазами, лицевая сторона не скошена / C-Let yivli, şamfersiz											
Art. No.	Grooved Outlet Size Вых. отверстие с пазом Çıkış boy (diş)		Header for Pipe Size Головная часть трубы, диам. Borulup anma genişliği		Outlet Length Длина выпуск. отверстия Çıkış uzunluğu	Inside Ø Внутренний Ø İç Ø çap	Outside Ø Внутренний Ø Dış çarı Ø	Wall Thickness Толщина стенки Düvar kalınlığı	Kg	UL	FM
	DN		DN		C mm	D mm	E mm	F mm			
GR25050NC	25	1"	50-65	2"-2.1/2"	81	30	33.4	3.38	0.125	✓	✓
GR25065NC			65-100	2.1/2"-4"	80					✓	✓
GR32050NC	32	1.1/4"	50-65	2"-2.1/2"	84	39	42.2	3.56	0.200	✓	✓
GR32080NC			80-100	3"-4"	81					✓	✓
GR32125NC			125-200	5"-8"	79					✓	✓
GR40050NC	40	1.1/2"	50	2"	88	45	48.3	3.68	0.350	✓	✓
GR40065NC			65	2.1/2"	85					✓	✓
GR40080NC			80-100	3"-4V	82					✓	✓
GR40125NC			125-200	5"-8"	80					✓	✓
GR50065NC	50	2"	65	2.1/2"	92	57	60.3	3.91	0.700	✓	✓
GR50080NC			80	3"	88					✓	✓
GR50100NC			100	4"	85					✓	✓
GR50150NC			150	6"	82					✓	✓
GR50200NC			200	8"	80					✓	✓
GR65065NC	65	2.1/2"	65	2.1/2"	114	69	76.2	5.16	0.900	✓	✓
GR65080NC			80	3"	98					✓	✓
GR65100NC			100	4"	91					✓	✓
GR65150NC			150	6"	85					✓	✓
GR65200NC			200	8"	83					✓	✓
GR80080NC	80	3"	80	3"	119	72	88.9	5.49	0.100	✓	✓
GR80100NC			100	4"	98					✓	✓
GR80150NC			150	6"	89					✓	✓
GR80200NC			200	8"	86					✓	✓
GR100100NC	100	4"	100	4"	159	85	114.3	6.02	0.125	✓	✓
GR100150NC			150	6"	124					✓	✓
GR100200NC			200	8"	118					✓	✓

Max. 20.68 bar [300 psi] for Sprinkler systems/для спринклерных систем/Max.20.68 bar [300 psi] sistemler için

TYCERTFP 03/07 Tyco reserves the right to change the contents without notice

RU Герметик для резьбы труб

TR Dişli borular için sızdırmaz dolgu maddesi



Model Permabond A1058				
Art. No.	Description Описание Tanımlama		Kg	WRC
A105825000	Tube /Тюбик /Tüp	250 ml	0.30	√
A105825025	Box /Коробка /Kutu	25x250 ml	7.50	√

DESCRIPTION:

Permabond A1058 is a highly viscous anaerobic sealant designed for use on threaded metal pipe connections.

The delayed cure allows components to be accurately aligned. Permabond A1058 provides an instant seal and can be applied more easily and faster than PTFE tape or hemp, saving on installation time.

Use Instructions:

Wipe male and female threads with a clean, dry rag to remove any grease and dirt.

Apply A1058 to the full circumference of the male thread to 1 and a half thread forms, ensuring that there is sufficient adhesive to fill the gaps & that it is positioned correctly.

For threaded parts of 4" diameter and above, apply a second bead half inch from the first bead or apply A1058 to both components.

Assemble the joints with tools in the normal way and wipe off any excess from the finished joint.

Описание:

Permabond A1058 - это анаэробный герметик с высокой вязкостью, предназначенный для использования в местах резьбовых соединений металлических труб.

Замедленное затвердевание позволяет точно совместить детали. Permabond A1058 обеспечивает мгновенную герметизацию, легче и быстрее наносится по сравнению с лентой из ПТФЭ или паклей, что позволяет сэкономить время при монтаже.

Указания по применению:

Протереть наружную и внутреннюю резьбу чистой сухой ветошью, удалив консистентную смазку и грязь.

Нанести герметик A1058 по всей окружности наружной резьбы на полуторную резьбу, обеспечив достаточное заполнение промежутков связующим материалом и точность расположения.

В случае с деталями, имеющими резьбу 4" и более нужно нанести герметик второй раз, отступив на полдюйма от первой нанесенной по окружности порции или нанести герметик A1058 на обе детали.

В обычном порядке произведите стыки с помощью инструмента и сотрите излишки материала с места стыковки.

Tanımlama:

Permabond A1058 yüksek derecede yapışkan, anaerobik ve yivli madeni boru bağlantılarında kullanılan sızdırmaz bir dolgu maddesidir.

Gecikmeli sertleşme süresi boru parçalarının doğru hizalanmasını mümkün kılmaktadır. Permabond A1058 anında sızdırmaz hale gelir. PTFE bandı veya kenevirten daha kolay ve daha hızlı kullanılabilirdiği için kurma süresini kısaltır.

Uygulama talimatları:

Erkek ve dişi dişleri temiz ve kuru bir bez parçasıyla siliniz ve herhangi bir yağ veya kir kalıntısını temizleyiniz.

A1058'i erkek dişleri tüm çapına ve bir buçuk daire derinliğine kadar sürünüz. Bu şekilde aralıkları kapatacak ve parçalarının doğru yerleşmesini sağlayacak yeterli miktarda yapışkan maddesi uygulanmış olur.

4" çapını geçen dişlerin parçaları için ilk yapışkan uygulamasına yarım inç ilerisinde bir miktar A1058 daha uygulayınız. Bunun dışında her iki parçaya da A1058 uygulayabilirsiniz.

Birleşen parçaları bildiğiniz şekilde monte ediniz ve ekleme yerlerinden çıkan herhangi bir yapışkan artığını siliniz.

Welding Necks Flanges

RU Сварные торцевые насадки

TR Kaynak yakası flanşlar



WELDING NECK FLANGE

Material: Carbon Steel SA150N [ANSI], DINc22.8 [PN10-PN16]
Материал: Углеродистая сталь SA150N [ANSI], DINc22.8 [PN10-PN16]
Madde: Karbon çelik SA150N [ANSI], DINc22.8 [PN10-PN16]

Material: Black
Материал: Черный
Madde: Siyah

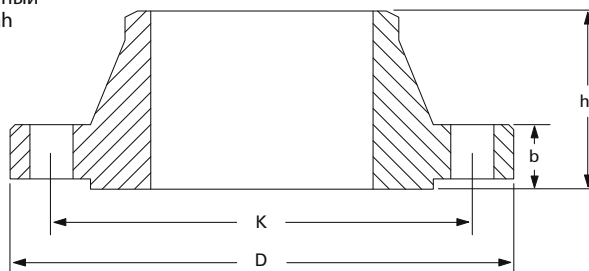

Art. No.	DN	Flange фланец Flanş	ØD mm	b mm	ØK mm	ØH mm	No. of Bolts Кол-во винтов Cıvata sayısı	Bolt Thread Резьба винтов Cıvata yivi	kg	
N43000765	65	2.1/2"	ANSI 125/150	177.80	22.35	139.70	19.05	4	UNC.5/8	4.10
N43000768	65	2.1/2"	PN10/16	185.00	18.00	145.00	18.00	4	M16	4.10
N43000895	80	3"	ANSI 125/150	190.5	23.88	152.40	19.05	4	UNC.5/8	4.90
N43000898	80	3"	PN10/16	200.00	20.00	160.00	18.00	8	M16	4.90
N430001145	100	4"	ANSI 125/150	228.60	23.88	190.50	19.05	8	UNC.5/8	6.80
N430001148	100	4"	PN10/16	220.00	20.00	180.00	18.00	8	M16	6.80
N430001415	125	5"	ANSI 125/150	254.00	23.88	215.90	22.35	8	UNC.3/4	8.60
N430001418	125	5"	PN10/16	250.00	22.00	210.00	18.00	8	M16	8.60
N430001685	150	6"	ANSI 125/150	279.40	25.40	241.30	22.35	8	UNC.3/4	10.6
N430001688	150	6"	PN10/16	285.00	22.00	240.00	22.00	8	M16	10.6
N430002195	200	8"	ANSI 125/150	342.90	28.45	298.45	22.35	8	UNC.3/4	17.6
N430002197	200	8"	PN10	340.00	24.00	295.00	22.00	8	M16	17.6
N430002198	200	8"	PN16	340.00	24.00	295.00	22.00	12	M16	17.6
N430002735	250	10"	ANSI 125/150	406.40	30.23	361.95	25.40	12	UNC.7/8	24.0
N430002737	250	10"	PN10	395.00	26.00	350.00	22.00	12	M20	24.0
N430002738	250	10"	PN16	405.00	26.00	355.00	26.00	12	M24	24.0
N430003245	300	12"	ANSI 125/150	482.60	31.75	431.80	25.40	12	UNC.7/8	36.5
N430003247	300	12"	PN10	445.00	26.00	400.00	22.00	12	M20	36.5
N430003248	300	12"	PN16	460.00	28.00	410.00	26.00	12	M24	36.5

Flange Bolting Kits

RU Набор для винтового соединения фланцев

TR Flanş civata seti



FLANGE BOLTING KIT

Material Gasket: SBR/FIBER
 Материал прокладки: SBR/FIBER
 Conta maddesi: SBR/LİF

Material Bolt: DIN931, Steel Quality 8.8, Zinc Plated
 Материал винтов: DIN931, сталь качества 8.8, оцинковка
 Civata maddesi: DIN931, çelik kalitesi 8.8, çinko kaplamalı

Material Nut: DIN934, Steel Quality, Zinc Plated
 Материал гаек: DIN934, высококачественная сталь, оцинковка
 Somun maddesi: DIN934, çelik kalitesi, çinko kaplamalı

Material Washer: DIN125-1A, Steel, Zinc Plated
 Материал шайб: DIN125-1A, сталь, оцинковка
 Rondela maddesi: DIN125-1A, çelik, çinko kaplamalı

Soft Gasket [EPDM]/Мягкая прокладка /yumuşak conta

DN	Art. No.	Art. No.	Art. No.	Bolt Size			
				PN10	PN16	ANSI	
				PN10	PN16	ANSI	
50	2"	FL0608	FL0608	FL0605	M16	M16	M16
65	2.1/2"	FL0768	FL0768	FL0765	M16	M16	M16
80	3"	FL0898	FL0898	FL0895	M16	M16	M16
100	4"	FL1148	FL1148	FL1145	M16	M16	M16
125	5"	FL1398	FL1398	FL1395	M16	M16	M20
150	6"	FL1688	FL1688	FL1685	M20	M20	M20
200	8"	FL2197	FL2198	FL2195	M20	M20	M20
250	10"	FL2737	FL2738	FL2735	M24	M24	M24
300	12"	FL3247	FL3248	FL3245	M24	M24	M24

Hard Gasket [Fiber]/Жесткая прокладка [волокно]/Sert conta [lif]

DN	Art. No.	Art. No.	Art. No.	Bolt Size			
				PN10	PN16	ANSI	
				PN10	PN16	ANSI	
50	2"	FLB0608	FLB0608	FLB0605	M16	M16	M16
65	2.1/2"	FLB0768	FLB0768	FLB0765	M16	M16	M16
80	3"	FLB0898	FLB0898	FLB0895	M16	M16	M16
100	4"	FLB1148	FLB1148	FLB1145	M16	M16	M16
125	5"	FLB1398	FLB1398	FLB1395	M16	M16	M20
150	6"	FLB1688	FLB1688	FLB1685	M20	M20	M20
200	8"	FLB2197	FLB2198	FLB2195	M20	M20	M20
250	10"	FLB2737	FLB2738	FLB2735	M20	M24	M24
300	12"	FLB3247	FLB3248	FLB3245	M20	M24	M24
350	14"	FLB3557	FLB3558	FLB3555	M20	M24	M27

Semi Lug Valve [JMC]/С монтажными проушинами [JMC]/Ara flanş [JMC]

DN	Art. No.	Art. No.	Art. No.	Bolt Size			
				PN10	PN16	ANSI	
				PN10	PN16	ANSI	
50	2"	FLS0607	FLS0607	FLS0607	M16	M16	M16
65	2.1/2"	FLS0767	FLS0767	FLS0767	M16	M16	M16
80	3"	FLS0897	FLS0897	FLS0897	M16	M16	M16
100	4"	FLS1147	FLS1147	FLS1147	M16	M16	M16
125	5"	FLS1397	FLS1397	FLS1397	M16	M16	M20
150	6"	FLS1687	FLS1687	FLS1687	M20	M20	M20
200	8"	FLS2197	FLS2198	FLS2198	M20	M24	M20
250	10"	FLS2737	FLS2738	FLS2738	M20	M24	M20
300	12"	FLS3247	FLS3248	FLS3248	M20	M24	M20

Mono Flange Valve /Клапан монофланца/Mono flanş vanası

DN	Art. No.	Art. No.	Art. No.	Bolt Size			
				PN10	PN16	ANSI	
				PN10	PN16	ANSI	
50	2"	FLW0607	FLW0607	FLW0605	M16	M16	M16
65	2.1/2"	FLW0767	FLW0767	FLW0765	M16	M16	M16
80	3"	FLW0897	FLW0897	FLW0895	M16	M16	M16
100	4"	FLW1147	FLW1147	FLW1145	M16	M16	M16
125	5"	FLW1397	FLW1397	FLW1395	M16	M20	M20
150	6"	FLW1687	FLW1687	FLW1685	M20	M20	M20
200	8"	FLW2197	FLW2198	FLW2195	M20	M20	M20
250	10"	FLW2737	FLW2738	FLW2735	M20	M24	M24
300	12"	FLW3247	FLW3248	FLW3245	M20	M24	M24